

Two-Rock

Classic Type

3

OWNERS MANUAL

Thank you for your purchase of a *Two-Rock* amplifier from *K&M Analog Designs, LLC*.

As a discerning guitarist, you know the road to great tone begins with great components.

Our Classic Design, carefully selected parts and hand-built approach combine to make an extremely versatile instrument.

Please take the time to read this manual. We hope it will answer any questions that you may have.

We extend a warm welcome to you as a member of a select group of musicians who have chosen a Two-Rock amplifier.

Front Panel Functions



Input Jack- High impedance input to the amplifier. Plug in your instrument here.

FET Gain- The FET (Field Effect Transistor) feature consists of a single stage high impedance preamp/buffer. This feature can be switched in and out via the front panel switch (“ON” is “up” position) or footswitch. This mode offers an additional buffered gain stage, and can be used to buffer the input from high output pickups or increase the signal of low output pickups. The FET GAIN control controls the amount of signal fed to the following stage(s) {gain control}

FET Switch- enables or defeats the FET feature. (“ON” is “up” position)

Treble Control- Adjusts the high frequency response. In the full counter-clockwise position, high frequencies are bypassed to ground. In the full clockwise position, high frequencies are allowed to pass to the next gain stage.

Bright Switch- Boosts the high frequency response. This is most effective when the input gain is set at 12 o’clock or lower. The effect is less dramatic as the input gain control is adjusted past the 12 o’clock position.

Middle Control- Adjusts the mid-range response. In the full counter-clockwise position, the tone will be somewhat “scooped” of mid-range response, emphasizing the highs and lows. In the full clockwise position, mid-range frequencies are allowed to pass to the next gain stage.

Mid Switch- Boosts the mid range frequency response.

Bass Control- Adjusts the bass response. In the full counter-clockwise position, low frequencies are cut. In addition, the response of the treble and mid-range controls is greatly reduced. In the full clockwise position, low frequencies are allowed to pass to the next gain stage.

Deep Switch- Boosts the low and low-mid frequencies. This is a low frequency contour switch, changing the low and low-mid response.

Input Gain- Adjusts the overall gain of the amplifier. Start with this control in the 12 o’clock position. Keep in mind that the amount of gain set here determines the signal level feeding the lead channel. Low gain settings of this control will require higher lead gain settings for the same amount of overdrive.

Clean Channel Master Volume- Adjusts the output level of the clean channel.

NOTE: All switches are ON in the “up” position

Q1/Q2- This switch allows you to choose between 2 completely different equalization settings. **Q1** is a lower gain setting, with extended midrange and bass available when used in conjunction with the middle and bass controls as well as the deep switch. This setting is suitable for any style requiring a pure clean tone with a nice round bottom and plenty of headroom.

Q2 is a higher gain setting, allowing a greater signal level to pass to the lead channel. This setting is suitable for any style requiring a clean to slightly distorted tone in clean mode, and more gain in the lead mode.

Lead Gain- Adjusts the input level (gain) of the lead channel.

Lead master- Adjusts the output level of the lead channel.

Lead Channel Switch- Sends the instrument signal through the lead circuit, adding extra stages of gain to the signal and enabling the lead gain and lead master controls. To enable foot switch control of this function, switch must be in the down position.

Bypass Switch- This switch bypasses the tone controls, increasing both level and mid-range response. To enable footswitch control of this function, switch must be in the down position.

Contour Control- The contour control is an active wide band sweep. In the 12 o'clock position, the amps' frequency response is flat. Counterclockwise rotation reduces high end response and increases low frequencies. Counterclockwise rotation decreases low end and increases the high frequency response. This control is very useful for maintaining preamp tone control settings, while allowing a global adjustment to compensate for differences in room acoustics, speaker cabinets, or bright to dark guitars (PRS Humbucker to Strat, for example). This control also actively reduces the articulation available, allowing a softer setting, or extremely open and revealing, depending on your individual style and requirements. The front panel contour control is assigned to the clean channel only. (See next page, **Lead Contour**)

Stand-by Switch- Should be in the "down" or "stand-by" position when you apply power to the unit. After a few seconds, place the switch in the "up" position to use the amplifier. You may leave the unit "powered up" and place this switch in the "stand-by" position to mute the output.

Indicator Lamp- This lamp will illuminate when the power switch is in the "up" position, indicating the unit is receiving A/C power.

NOTE: All switches are ON in the "up" position

Rear Panel Functions



A/C Input- Connects the amplifier to A/C power via the power cord supplied. Unless otherwise specified, your amplifier is designed to operate on 120 volts A/C, 60 cycles, ONLY.

Fuse- See Fuse Chart

Power Switch- Turns power on.

Class A/B Switch (50 Watt)- on Type 3 models the HIGH power mode is 50 watts (class A/B operation). The LOW power mode is 22 watts (Class A operation.)

Feedback Selector- In the up position, the output stage negative feedback is taken from the 16 ohm speaker jack. In the center off position, there is no feedback in the circuit. In the down position, the output stage negative feedback is taken from the 8 ohm jack.

Speaker Output Jacks- There are 3 speaker output jacks; 4,8, and 16 ohms. NEVER OPERATE YOUR AMPLIFIER WITHOUT A PROPER SPEAKER LOAD CONNECTED. Be sure to match the impedance of your cabinet with the impedance (output) of the amplifier.

Lead Contour- This contour control has the same function as the front panel control, but is assigned to the lead channel only.

Footswitch Jack- The footswitch connects here. The clean/lead, tone bypass, and FET functions can be activated via the footswitch. The respective front panel switches must be in the “off,” or down position, to enable the footswitch functions.

Effects Send- Use this jack to send the amplifiers signal to outboard effects.

Effects Return- Use this jack to connect the output of your effects to the amplifier.

Lead Trim- This control is a fine adjustment at the input stage of the lead channel. High clean gain settings allow a higher signal level to the lead stage, and this control can smooth out or increase the aggressive nature of the lead channel in conjunction with the lead gain control.

Feedback max/off/min- This switch defeats(center off) the internal negative feedback circuit located in the preamp section.

The effect is subtle and becomes more apparent as you familiarize yourself with various settings. “Max” setting is maximum feedback, most effective when using high output humbucking or active pickups. “Off” disengages the feedback circuit, and “Min” adds negative feedback suitable for low output single coil pickups. These settings are recommendations only; we suggest you experiment with various combinations of settings of both preamp and output negative feedback. You can change the degree of articulation, compression, and “bloom” characteristics of the amp with these features.

S/N- Your serial number is located here. We strongly suggest that you record this number and have it

Tube Complement

V1- 12AX7, Rhythm channel
V2- 12AX7, Lead Channel
V3- 12AX7, Phase Inverter
V4, V5- 6L6GC, Output
V6, V7- 5AR4, Rectifier Tubes

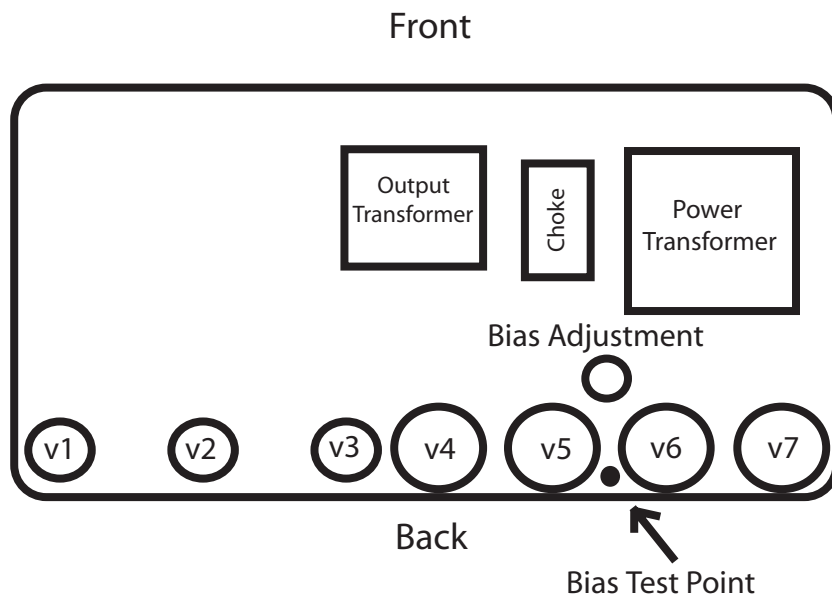

Each fine production tube is tested and matched to our exacting specifications. External bias adjustment and test points are located on the chassis near the output tube sockets. A digital voltmeter and small screwdriver are required for bias adjustment.

BIAS ADJUSTMENTS:

Power up unit and connect proper speaker load.

Set master volumes and effects return controls to zero.

DO NOT apply any signal to the input during the biasing procedure!

Take unit off standby and allow a few seconds for the circuit to stabilize.

Set voltmeter to Millivolt scale (or lowest volt scale 60 millivolts=.060 volts.)

With meter grounded to chassis and + probe at test point, measure voltage.

A reading of 0.055 to 0.060 volts is normal for 50 Watt amplifiers with (2) 6L6's. A reading of 0.115 to 0.120 volts is normal for 100 Watt amplifiers with (4) 6L6's. If not in this range, adjust by turning bias screw **SLOWLY** a small amount. **Do not set above .070!**

For other tube types (5881, 6550, EL34) check with the manufacturer or contact us for recommendations.

Settings higher than .065 with 6L6 tubes may cause premature tube wear and possibly damage the amplifier.

Keep in mind that tubes vary in quality, and some tubes can handle upwards of 40 ma each (a reading at the test point of .080!) However, to be on the safe side, use the above as a guide.

NOTE: Some amps are equipped with 2 bias pots, one for low power, the other for high power. Adjust bias in both hi and low power settings!

NOTE: Some amps are Class A/AB. In LOW POWER MODE(CLASS A), you will not get a proper reading-adjust bias in high power mode only.

WARNING! No user serviceable parts inside! Refer to qualified service person only.

LINE CORD- For your safety, connect to grounded A/C receptacle only.

Fuse Chart

All Fuses are 3AG Type 250 Volt, SLO-BLO

Export 100 Volt

3.5- 100 Watt 4x6L6
2.8- 50 Watt 2x6L6
2.25- Jet and Jet Signature

Domestic Fuses:

3.25- 100 Watt 4x6L6
2.5- 50 Watt 2x6L6
2- Jet and Jet Signature

Export 220, 230, 240 Fuses:

1.6- 100 Watt 4x6L6
1.25- 50 Watt 2x6L6
1- Jet and Jet Signature

Footswitch Functions

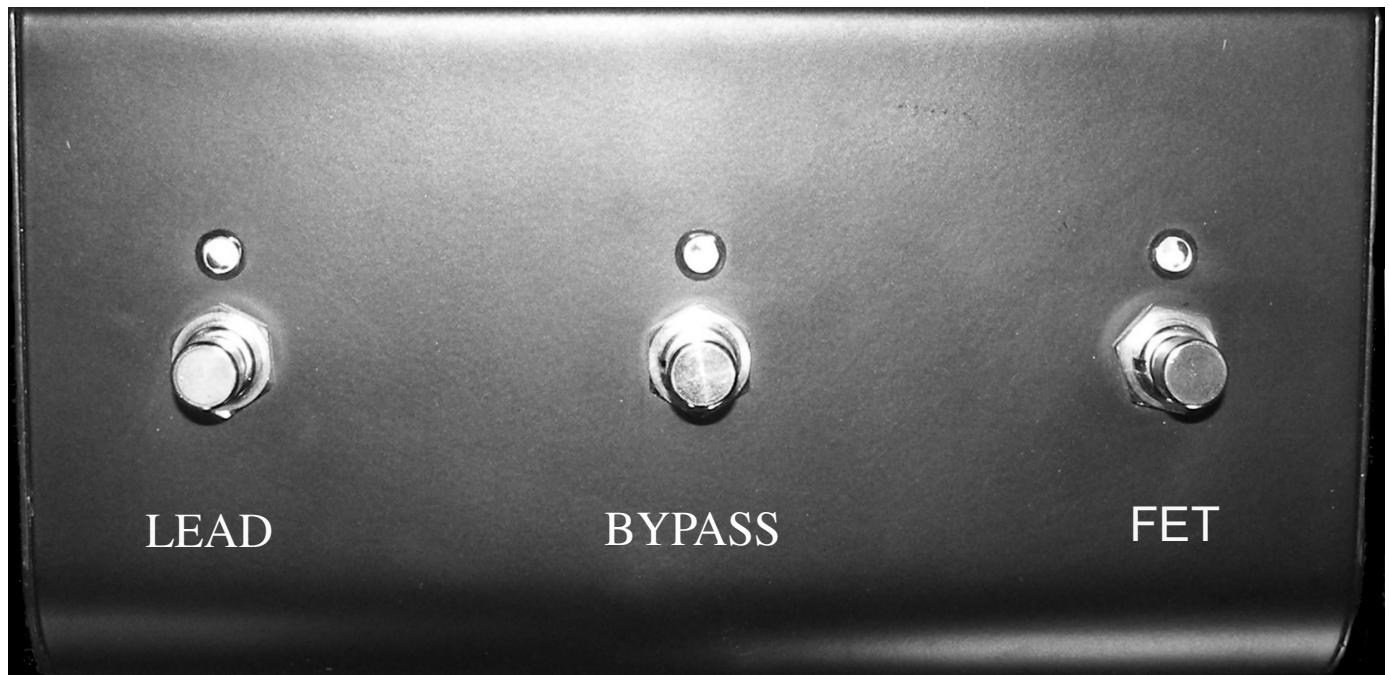

LEAD-	Blue LED
BYPASS-	Red LED
FET-	Green LED

K&M Analog Designs amplifiers are brought to you by Bill Krinard and Joe Mloganoski.

We know your new *Two-Rock* amplifier will provide many hours of enjoyment and inspiration in the years to come. This manual is a resource for some of your questions. Please contact us with any other questions or comments that you may have. We look forward to hearing from you!

PHONE: 1(707)584-TONE (8663) (M-F 9am-5pm PST)

FAX: 1(707)584-8661

ADDRESS: K&M Analog Designs, LLC
619 Martin Avenue, Suite 6
Rohnert Park, CA 94928

E-MAIL: Joe Mloganoski, Product Specialist
joe@two-rock.com

Bill Krinard, Chief Engineer
bill@two-rock.com

INTERNET: www.two-rock.com

PRECAUTIONS:

DO NOT expose to rain or any other moisture.

DO NOT use cleaning solvents. Wipe exterior with a clean, dry cloth only.

Refer servicing to a qualified service technician.

This is a product of

K&M Analog Designs, LLC

619 MARTIN AVENUE, SUITE 6

ROHNERT PARK, CA 94928

707-584-8663

www.two-rock.com

SERIAL NUMBER: _____